

LEVELING ADJUSTABLE HEIGHT ALUMINUM GANTRY - AHA-2-12-8-ALO

APPROX WEIGHT: 232.32 lbs.
DOES NOT INCLUDE WEIGHT OF POWER OR PACKAGING!!!

*** ANY ADDITIONS, DELETIONS, OR OMISSIONS MUST BE CORRECTED ON THIS DRAWING AS THIS DRAWING WILL BE CONSIDERED ALL INCLUSIVE ***
ALL GRAPHICS PROVIDED ARE FOR REFERENCE ONLY. IF CERTAIN DIMENSIONS ARE CRITICAL PLEASE VERIFY THOSE DIMENSIONS WITH YOUR SALESPERSON

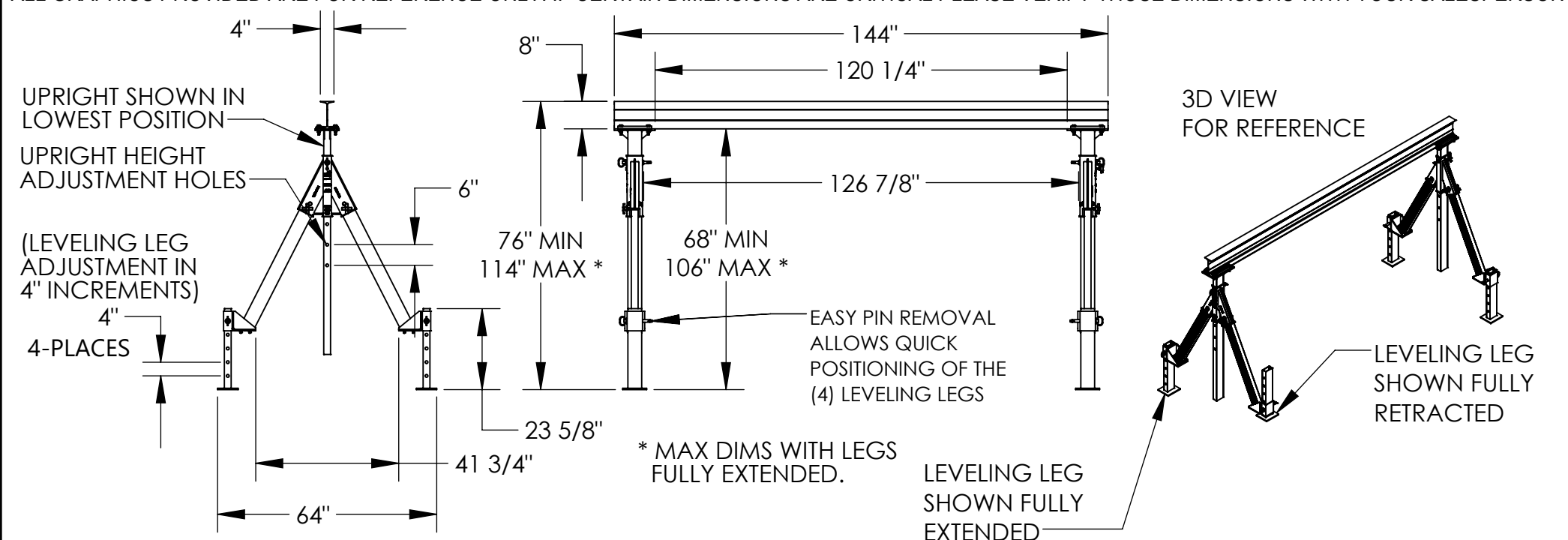

STANDARD FEATURES

- MODEL NUMBER IS AHA-2-12-8-ALO
- CAPACITY IS 2,000 LBS.
- BASE WIDTH IS 64"
- MAX OVERALL HEIGHT IS 114" *
- I-BEAM SIZE IS 8" TALL WITH 4" FLANGE WIDTH
- OVERALL I-BEAM LENGTH IS 144"
- USABLE I-BEAM LENGTH IS 120 1/4"
- LEVELING LEG HEIGHT IS INDIVIDUALLY ADJUSTED UP TO 16" MAX. TO LEVEL CRANE UNDER I-BEAM HEIGHT MAY BE ADJUSTED IN 6" INCREMENTS USING THE 6 HOLES IN THE UPRIGHTS ADJUSTABLE UNDER I-BEAM HEIGHT 68" MIN. 106" MAX. *
- CRANE MAY BE TAKEN APART AND BUNDLED WITH (2) INCLUDED STRAPS FOR EASY TRANSPORT
- ALUMINUM CONSTRUCTION

SPECIAL FEATURES

NONE

DIMENSION TOLERANCE ± 1/4"

APPROVAL

I, THE UNDERSIGNED, AGREE THAT THE PRODUCT AS REPRESENTED SATISFIES DESIGN AND DIMENSION REQUIREMENTS. I ALSO ACKNOWLEDGE MY DUTY TO CONFIRM PRODUCT AND INSTALLATION COMPLIANCE WITH ALL APPLICABLE FEDERAL, STATE AND LOCAL REGULATIONS AND STANDARDS.

UNITS REQUIRING APPROVAL DRAWINGS OR MODIFIED ARE NON-RETURNABLE

[] As drawn [] As marked

Signed: _____ Date: _____

Printed Name: _____

LEAD TIME WILL START UPON RECEIPT OF SIGNED APPROVAL DRAWING

DISTRIBUTOR'S NAME:		P.O.#
VESTIL MANUFACTURING		X
DRAWN BY: MTS		W.O.#
DATE: 10/11/2019		X
REFERENCE: X	SCALE: 1:42	SALES: X
QUOTED LEAD TIME: X	QUOTE # X	FILE NAME:
		28-007-423